



ARSENO M300

Front Loading High Production Sweeper



- **Front loading provides speed and efficiency**
- **Operating speed of up to 20 Km/hr (11 MPH)**
- **Travelling speed of up to 90 Km/hr (50 MPH)**
- **Full visibility operator's cab with riser and safe access**
- **Ergonomic console and steering column**
- **Easy access to all components for maintenance**
- ***Patent pending**

Technical specifications Front loading sweeper

ARSENO M300

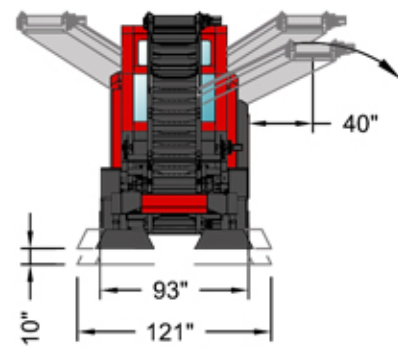
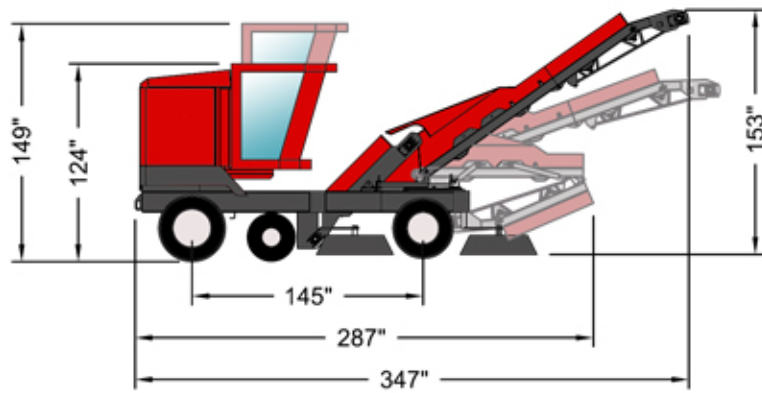

Weight	Basic unit weight - no options: 9,525 Kg (21,000 lbs)
Engine	Cummins ISC 330 HP – 1,100 ft.lbs. torque @ 1400 RPM Air to air cooler and radiator
Performance	Up to two (2) metric tons per minute into conveyor
Speed	Traveling speed of up to 90 Km/hr (50 MPH)
Hydraulics	Hydrostatic double pump with Load Sensing implement pump Hydraulic reservoir:..... 3,780 l (100 US Gal.) Suction strainer:..... 125 mesh Pressure filters:..... 10 microns Return filters:..... 10 microns Oil Cooler with thermostatic control
Electrical	12 VDC system One (1) 8D type battery 1,100 amps 120 amps alternator Safety fuses for best protection
Powertrain	Rear axle with two (2) speeds differential Two (2) speeds hydraulic motor (hydrostatic) Front steering axle
Suspension	Front spring suspension; Rear axle is rubber cushioned
Brake	Front and rear axles hydraulic brake over hydrostatic braking
Tires	Front : 9 X 22.5 Rear : 315 X 80 X 22.5
Loading conveyor	Heavy duty belt with 3/4" cleats for best performance with guiding system Variable speed on belt for dust control Pivot mounted for loading adjustment - hydraulic
Fuel tank	Diesel fuel, 180 litres (48 US gals)
Water tank	For dust control mist - 890 litres (235 US gals);
Options	Front rotating brushes for best performance Anti-collision radar system Cruise control system Back-up camera system Adjustable mounting for brushes Rotating beacon and other safety lighting Wireless control for loading conveyor adjustment and fold-down

*Patent pending



www.tanguay.cc

625, route de l'Aéroport
Roberval QC G8H 2M9 CANADA

Tél : 418.251.3152
Tel : 800.463.9856
Fax: 418.275.3376

Imprimé au Canada / Printed in Canada